

i - SERIES

MINI SCREW COMPRESSOR PACKAGES

MYCOM



MAYEKAWA

DIMENSIONS & WEIGHT

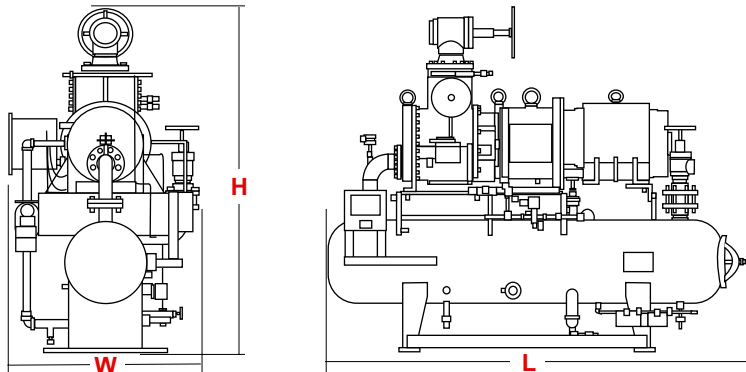

MODEL#	CFM@3550rpm	TR	HP	L	H	W	WEIGHT
i125S	139	50	58	101	83	46	3200
i125L	210	75	85	101	83	46	3200
i160S	294	109	122	101	83	46	3200
i160M	367	136	147	118	91	46	3800
i160L	441	163	175	118	91	46	3800

* Design and specifications subject to change without notice.

1. Rating basis: R-717, 3550RPM, thermosiphon oil cooling, +20 F (-8.7 C) evaporating temperature, 95 F (35 C) condensing temperature, 10 F (5.5 C) liquid subcooling and 0 F suction superheat. 0 Psi pressure drop, without use of the economizer port.
2. Physical data based on oil separator, suction valve train and discharge valve train designed for operation at -50 F < T_{evap} < +20 F and 85 F < T_{cond} < 105 F.
3. Consult factory for liquid injection ratings and dimensions.

OPTIONS

SIMPLE AND COST EFFECTIVE MYPRO-IP PANEL

For customers who may require minimal control options, the MYPRO - IP microprocessor panel is furnished on I-Series units with Modbus-RTU communication protocol available as an option.

DUAL i-SERIES PACKAGE

For additional space reduction, Mycom can furnish two I-Series compressors on one separator with dual controls as one unit. Contact your factory representative for more information.

ENGINEERED SYSTEM SKID

Mycom can provide engineered chiller skids using I-Series compressor units for any fluid chilling requirements.

FEATURES

“SIMPLE IS THE BEST” DESIGN

Unlike some screw compressors with hydraulic slide valve systems, this compressor has 50, 75 and 100% step loading and unloading like reciprocating compressors. Less moving parts ensure more reliability in operation. The I-Series is perfect when simple refrigeration systems are installed.

PERFECT FOR VFD

Because of its simplicity in structure the compressor is a perfect fit for suction pressure control by VFD (Variable Frequency Drive).

MOTOR FLANGE MOUNTING

Motor flange mounting eliminates the need to periodically check coupling alignment that may reduce premature shaft seal failure.

NO OIL PUMP REQUIRED

With the i-series, the oil pump is only required on booster applications.

NO OIL PUMP REQUIRED

With the i-series, the oil pump is only required on booster applications.

OIL COOLER

Thermosiphon, water-cooled and electronic liquid injection oil cooler are available.

MYPRO-CP4 MICRO PANEL

CP4 panel ensures all necessary safeties for the package and allows for MODBUS communication protocol.

MAYEKAWA NORTH AMERICAN GROUP

MYCOM www.mycomus.com / www.mycomcanada.com

Torrance, CA Tel: (310) 328-1362 Fax: (310) 782-6759
 Modesto, CA Tel: (209) 545-9752 Fax: (209) 545-3654
 San Antonio, TX Tel: (210) 599-4536 Fax: (210) 599-4538
 York, PA Tel: (717) 779-0138 Fax: (717) 779-0109
 Montvale, NJ Tel: (201) 307-9199 Fax: (201) 307-1566
 Seattle, WA Tel: (206) 284-9280 Fax: (206) 284-7230

(Canada)
 Vancouver, BC Tel: (604) 270-1544 Fax: (604) 270-9870
 Toronto, ON Tel: (905) 564-0664 Fax: (905) 564-7614